

HEAVY-DUTY LARGE VOLUME STORAGE TANKS MODEL UGV CUSTOM BUILT

Large volume tanks are designed for storing potable water.

FEATURES

SIZES FROM 120 TO 4,000 GALLONS

All tanks are constructed to the requirements of the ASME Code. These ASME Code tanks are available at 125 & 150 PSI working pressure. Consult factory for tanks with special configurations.

LINING AND COATINGS

Each lining and coating has particular capabilities and limitations. Thorough investigation on the service life of steel tanks with protective coatings or linings has led to the recommendation of the following linings:

- Glass Lined — All internal surfaces exposed to water are glass lined per ASME HLW Code procedures.
- Cement Lined — Cement lining consists of a specially formulated cement applied over the interior of the vessel. Cement lined tanks are recommended when storing water at 180°F or higher.
- Please consult the factory for recommendations on the uses of linings for specific applications. All tanks receive one prime coat of paint on external surface. Contact your local State representative for severe or unusual applications that may require other materials.

CATHODIC PROTECTION

- Glass lined are furnished with anodes designed for maximum protection.

CUSTOM TANK OPENINGS

- All tanks will be supplied with the fittings located as indicated on the drawings unless specified otherwise. Custom tank opening sizes and locations can be provided as per your specification.

INSPECTION OPENINGS

- 12"x16" manhole or 4"x6" handhole are available as options on diameters 36" and below.
- 2 each 2" ASME inspection openings are standard on tanks 36" diameter and below.
- 12"x16" ASME inspection openings are standard on tanks with 42" diameters and above.

TANK OPTIONS

- Manholes / Handholes
- Additional / Custom Tank Openings
- Lifting Lugs
- Angle Legs
- Ring Base
- Horizontal Tank Saddles
- Factory Jacketing and Insulation
- Tube bundles
- Cement Lining

Attention: Significant changes have been made to some models. Please note that this spec sheet refers specifically to models manufactured in Lebanon, TN

MODELS UGV-20-120 THROUGH UGV-72-4000

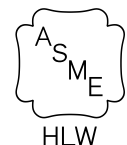
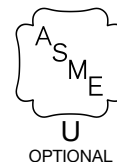

SOLID. STATE.



STORAGE TANK SELECTION

Model Number	Gallons	Dimensions			Shipping Weight (lbs.)		
		Diameter	Vertical Height	Horizontal Length	125 psi	150 psi	Cement Lined
UGV24-0120-*A125	118	24"	64"	60"	368	368	-
UGV24-0140-*A125	141	24"	76"	72"	428	428	-
UGV24-0200-*A125	188	24"	100"	96"	556	556	-
UGV24-0250-*A125	235	24"	124"	120"	684	684	-
UGV28-0175-*A125	175	28"	65"	-	353	353	-
UGV28-0200-*A125	200	28"	76"	-	488	488	-
UGV30-00150-*A125	147	30"	52"	48"	400	400	695
UGV30-0185-*A125	184	30"	64"	60"	468	468	812
UGV30-0220-*A125	220	30"	76"	72"	548	548	958
UGV30-0250-*A125	257	30"	87"	83"	628	628	1,103
UGV30-0300-*A125	294	30"	100"	96"	701	701	1,242
UGV30-0375-*A125	367	30"	124"	120"	868	868	1,540
UGV36-0275-*A125	265	36"	64"	60"	577	577	995
UGV36-00325-*A125	318	36"	76"	72"	673	673	1,173
UGV36-0400-*A125	370	36"	87"	83"	770	770	1,343
UGV36-00425-*A125	423	36"	100"	96"	866	866	1,513
UGV36-0500-*A125	528	36"	124"	120"	1,058	1,058	1,861
UGV42-0450-*A125	432	42"	76"	72"	795	909	1,385
UGV42-0500-*A125	504	42"	88"	84"	908	1,050	1,587
UGV42-0600-*A125	576	42"	100"	96"	1,020	1,190	1,790
UGV42-0750-*A125	720	42"	124"	120"	1,245	1,470	2,195
UGV42-0900-*A125	864	42"	148"	144"	1,470	1,751	2,601
UGV42-1000-*A125	1,008	42"	172"	168"	1,695	2,031	3,006
UGV48-0500-*A125	500	48"	73"	69"	1,062	1,062	1,856
UGV48-0700-*A125	658	48"	88"	84"	1,346	1,346	2,124
UGV48-0750-*A125	752	48"	100"	96"	1,507	1,507	2,392
UGV48-0950-*A125	940	48"	124"	120"	1,828	1,828	2,918
UGV48-1150-*A125	1,128	48"	148"	144"	2,150	2,150	3,444
UGV48-1300-*A125	1,315	48"	172"	168"	2,471	2,471	3,970
UGV54-1000-*A125	951	54"	100"	96"	1,721	1,972	2,729
UGV54-1200-*A125	1,189	54"	124"	120"	2,083	2,423	3,320
UGV54-1450-*A125	1,427	54"	148"	144"	2,451	2,881	3,919
UGV54-1700-*A125	1,665	54"	172"	168"	2,807	3,326	4,511
UGV54-1900-*A125	1,903	54"	196"	192"	3,168	3,777	5,102
UGV54-02150-*A125	2,141	54"	220"	216"	3,530	4,228	5,701
UGV60-1500-*A125	1,469	60"	172"	168"	3,749	4,425	5,658
UGV60-1750-*A125	1,763	60"	196"	192"	4,231	5,026	6,394
UGV60-2000-*A125	2,056	60"	172"	168"	3,749	4,425	5,658
UGV60-2400-*A125	2,350	60"	196"	192"	4,231	5,026	6,394
UGV60-2650-*A125	2,644	60"	220"	216"	4,713	5,628	7,130
UGV72-2100-*A125	2,115	72"	124"	120"	3,416	3,904	5,104
UGV72-2500-*A125	2,538	72"	148"	144"	3,995	4,627	5,995
UGV72-3000-*A125	2,961	72"	172"	168"	4,575	5,350	6,885
UGV72-3400-*A125	3,384	72"	196"	192"	5,154	6,073	7,767
UGV72-4000-*A125	3,807	72"	220"	216"	5,733	6,795	8,658

* For H e.g. (UGV42-1000-HA125) or V e.g. (UGV48-0700-VA125)

Specify Horizontal or Vertical installation H or V (after the 2nd dash)

Use J for Jacketed.

For Epoxy use E, for Cement use C and for unlined, U. UEV72-4000-*A125 for Unjacketed Glass... or JUV72-4000-*A125 for Jacketed, Unlined.

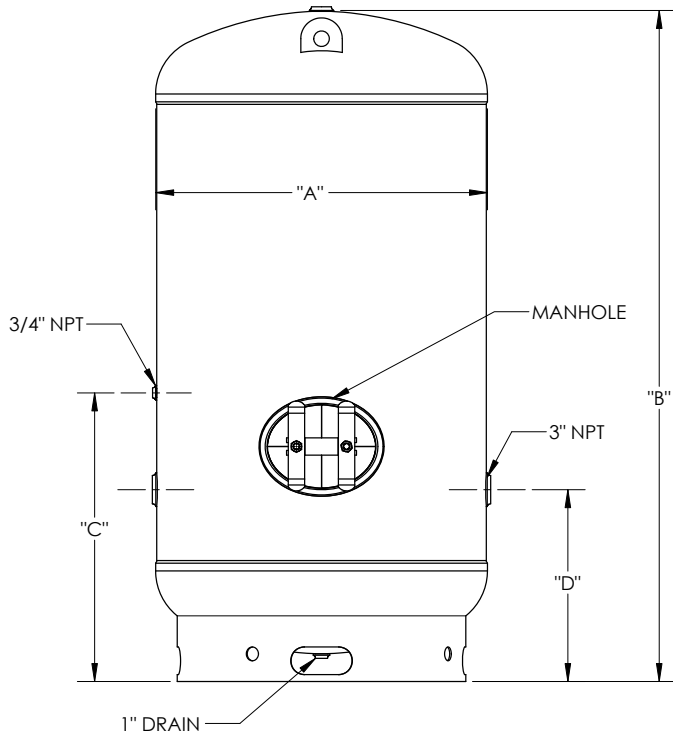

Diameter	C	D
24	16.75	11
28	17.375	11.62
30	31.875	15.875
36	33.375	17.375
42	34.875	18.875
48	36.875	20.875
54*	38.375	22.375
60	39.875	24.5
72	42.375	27

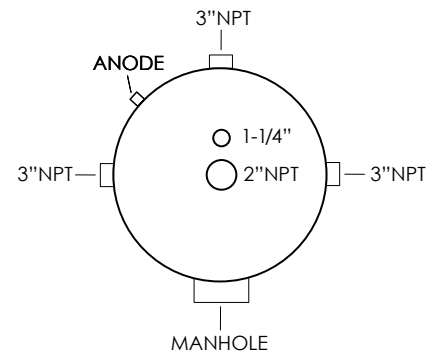

NOTE:
 SPECIFY FOR HORIZONTAL OR VERTICAL INSTALLATION.
 2 each 2" ASME inspection openings are standard on tanks 36" diameter and below.
 12"x16" ASME inspection openings are standard on tanks with 42" diameters and above.

Diameter	C	D
24	24.625	6
30	26.5	6
36	28	12
42	29.5	12
48	31.5	12
54	33	12
60	34.5	12
72	37	12

24" & 28" DIAMETER HORIZONTAL TANKS

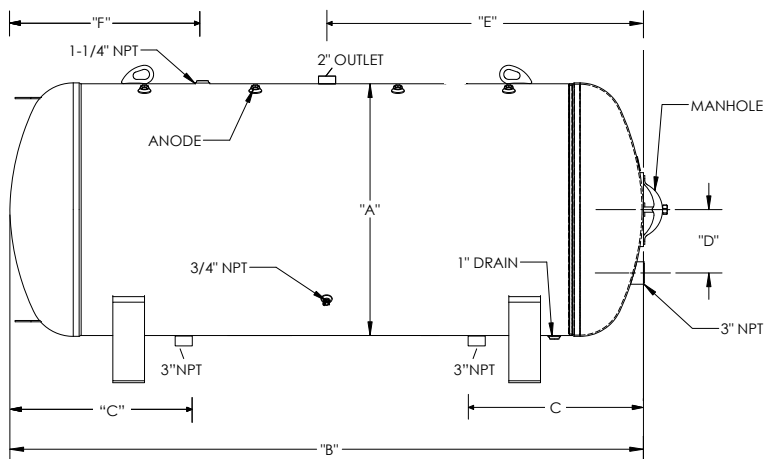

30" - 72" DIAMETER HORIZONTAL TANKS

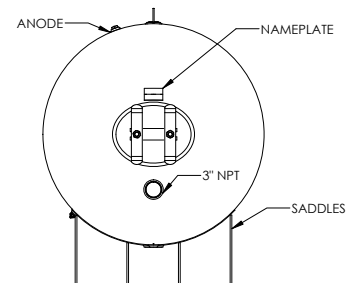

OPTIONAL TANK SADDLES FOR HORIZONTAL TANK INSTALLATIONS

TANK SADDLE DIMENSIONS

Tank Diameter
 30 36 42 48 54 60 72

A 21" 25" 29" 34" 48" 52" 62"

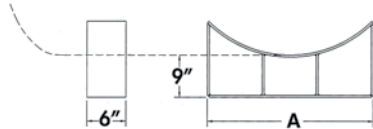

NOTE: Alternate saddle heights are available. (Consult factory)

TANK SADDLES

State PART NO.	Saddle Descriptions
100170345	SADDLE,TANK,24",9"CLR,P-1
100170349	SADDLE,TANK,30",9"CLR,P-1
100170338	SADDLE,TANK,28",9"CLR,P-1
100170352	SADDLE,TANK,36",9"CLR,P-1
100170355	SADDLE,TANK,42",9"CLR,P-1
100170358	SADDLE,TANK,48",9"CLR,P-1
100170361	SADDLE,TANK,54",9"CLR,P-1
100170365	SADDLE,TANK,60",9"CLR,P-1
100170371	SADDLE,TANK,72",9"CLR,P-1

FACTORY INSULATION OPTIONS

Factory Jacketed and Insulation

- **INSULATION** — Entire tank is surrounded with high-density fiberglass insulation to reduce costly heat loss; non-sagging and vermin-proof.
- **CABINET** — Heavy gauge painted steel.
- Adds 4" to the round jacketed and 6" to the square jacketed diameter of the tank and 2" to height.



OUTDOOR FOAM INSULATION

- **INSULATION** — Entire tank is sprayed with minimum of 2" high-density polyurethane foam insulation that forms a watertight jacket that is approved for outdoor use.
- Adds 4" to the diameter of the tank and 2" to the height.

Note: Minimum foam insulation thickness is 2"; however, since tank is hand sprayed, insulation thicknesses may be greater in some areas giving the finished tank an uneven but watertight surface.

LIMITED WARRANTY

If the tank should leak anytime during the first five years, under the terms of the warranty, State will repair or replace the tank; installation, labor and handling extra.

SUGGESTED SPECIFICATION

SAMPLE SPECIFICATION FOR CUSTOM-LINE STORAGE TANKS WHEN JACKETED OR INSULATED THESE MODELS MEET OR EXCEED THE THERMAL EFFICIENCY AND STANDBY LOSS REQUIREMENTS OF ASHRAE 90.1B (CURRENT STANDARD).

ASME storage tank to be State Custom-Line model _____. Capacity to be _____ gallons with a diameter of _____ inches. Tank(s) shall be constructed and stamped according to ASME specifications for _____ psi working pressure. Manhole (12"x16"), handhole (4x6) or inspection openings (2-2") shall be installed in accordance with ASME code requirements and manufacturer(s) standard practice. Tank to be constructed of carbon steel _____. Lining shall be (glass, cement) _____. Tank(s) lined with (glass, cement) _____ lining shall be equipped with the number and size of anode rod(s) sufficient to provide adequate protection for the tank lining. Tank shall be (vertical, horizontal) _____ design and provided with (four) _____ ring base, _____ saddles.

FOR MORE INFORMATION ON CALL 1-800-365-0024. STATE WATER HEATERS RESERVES THE RIGHT TO MAKE PRODUCT CHANGES OR IMPROVEMENTS WITHOUT PRIOR NOTICE.